

# Hall Effect Current Sensors L18P\*\*\*S12 Series

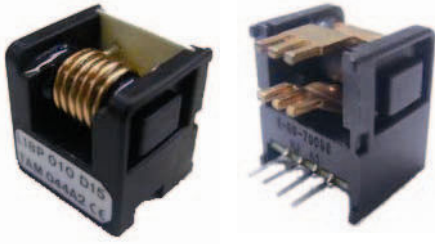

## Features:

- Open Loop type
- Printed circuit board mounting
- Integrated primary
- Unipolar power supply
- Busbar version from 40A to 60A
- Insulated plastic case according to UL94V0
- Regulated offset voltage

## Advantage:

- Excellent accuracy and linearity
- Wide nominal current range
- Low temperature drift
- Wide frequency bandwidth
- No insertion loss
- High Immunity To External Interference
- Optimised response time
- Current overload capability

## Specifications

$T_A=25^{\circ}\text{C}$ ,  $V_{CC}=+12\text{V}$ ,  $R_L=10\text{k}\Omega$

Parameters	Symbol	L18P003 S12	L18P005 S12	L18P010 S12	L18P015 S12	L18P020 S12	L18P025 S12	L18P030 S12	L18P040 S12	L18P050 S12	L18P060 S12
Rated current	$I_f$	3A	5A	10A	15A	20A	25A	30A	40A	50A	60A
Maximum Current	$I_{fmax}$	$I_f \times 1.25$									
Output Voltage	$V_{OUT}$	$V_{OE} \pm 4.0\text{V} \pm 0.045\text{V} @ \pm I_f$									
Offset Voltage <sup>1</sup>	$V_{OE}$	$2.5\text{V} \pm 0.035\text{V} @ I_f = 0\text{A}$									
Accuracy <sup>2</sup> @ $I_f$	$X$	$\pm 1\%$									
Output Linearity	$\epsilon_L$	$\leq \pm 1\% @ I_f$									
Power Supply	$V_{CC}$	$+12\text{V} \pm 5\%$									
Consumption Current	$I_C$	$\leq 15\text{mA}$									
Response Time	$t_r$	$\leq 5\mu\text{s} (@ di/dt = 10\text{A} / 5\mu\text{s})$									
Output Temperature Characteristic <sup>2</sup>	$TCV_{OUT}$	$\leq \pm 2.0\text{mV}/^{\circ}\text{C}$									
Offset Temperature Characteristic	$TCV_{OE}$	$\leq \pm 1.5\text{mV}/^{\circ}\text{C}$									
Hysteresis error	$V_{OH}$	$\leq 25\text{mV} (0\text{A} \leftrightarrow I_f)$									
Withstand Voltage	$V_d$	AC3000V for 1minute (sensing current 0.5mA), inside of through hole $\leftrightarrow$ terminal									
Insulation Resistance	$R_{IS}$	$> 500\text{M}\Omega$ (500V DC), inside of through hole $\leftrightarrow$ terminal									
Frequency Bandwidth <sup>3</sup>	$f$	DC .. 50kHz									
Operating Temperature	$T_A$	$-10^{\circ}\text{C} \sim +80^{\circ}\text{C}$									
Storage Temperature	$T_S$	$-20^{\circ}\text{C} \sim +85^{\circ}\text{C}$									

<sup>1</sup>  $V_{OE}$  is fixed (independent of  $V_{CC}$ ) — <sup>2</sup> Without offset — <sup>3</sup> Small signal only to avoid excessive heating of magnetic core

## Electrical Performances

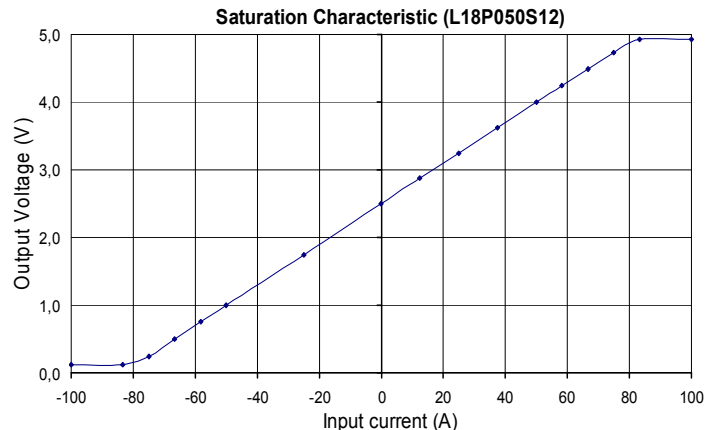
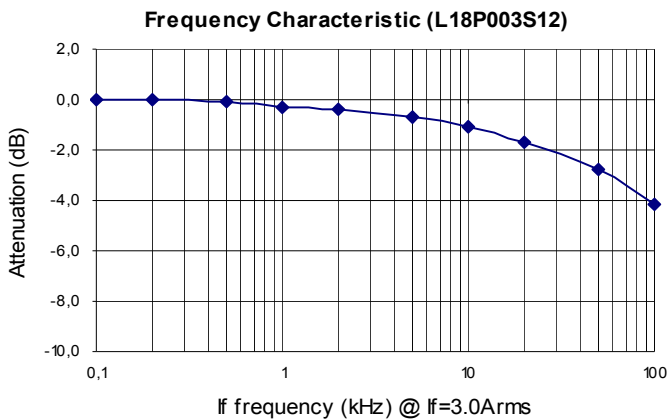

# Hall Effect Current Sensors L18P\*\*\*S12 Series

## Mechanical dimensions in mm

### Terminal Pin Identification

- 1: GND
- 2: GND
- 3: +V<sub>CC</sub>
- 4: Output
- 5: Primary input current (+)
- 6: Primary input current (-)

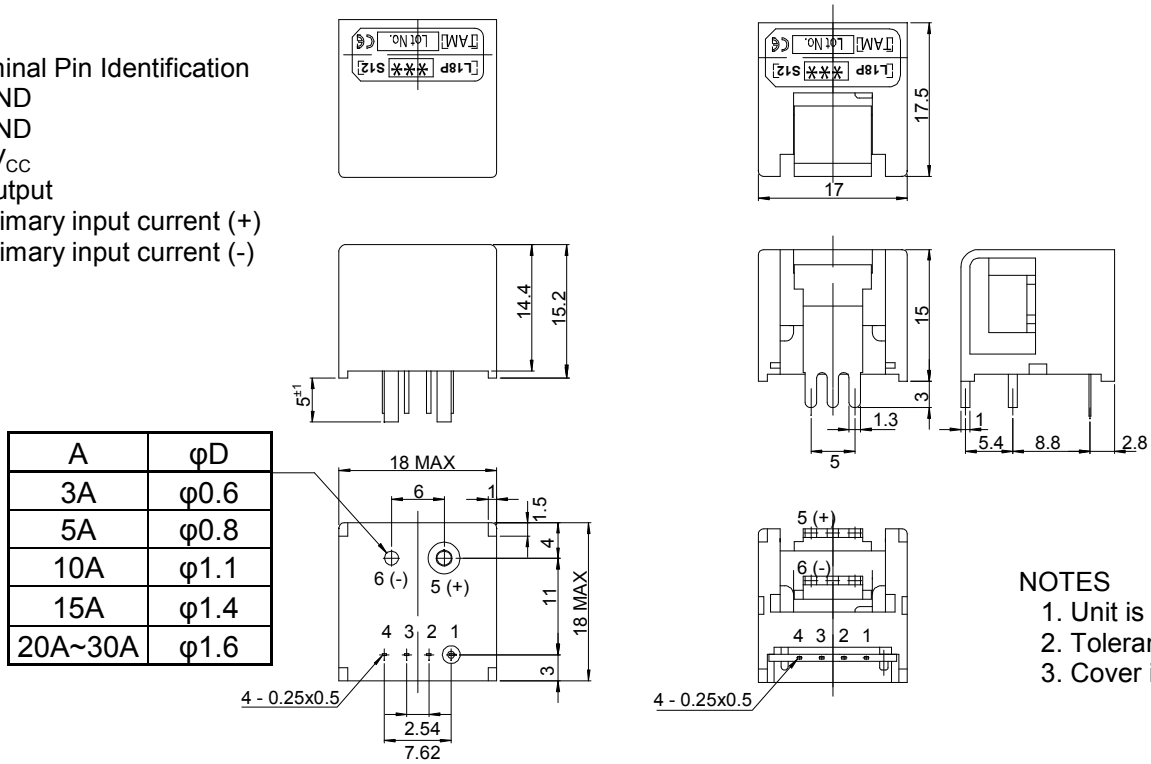

### NOTES

- 1. Unit is mm
- 2. Tolerance is 0.5mm
- 3. Cover is optional

## Electrical connection diagram

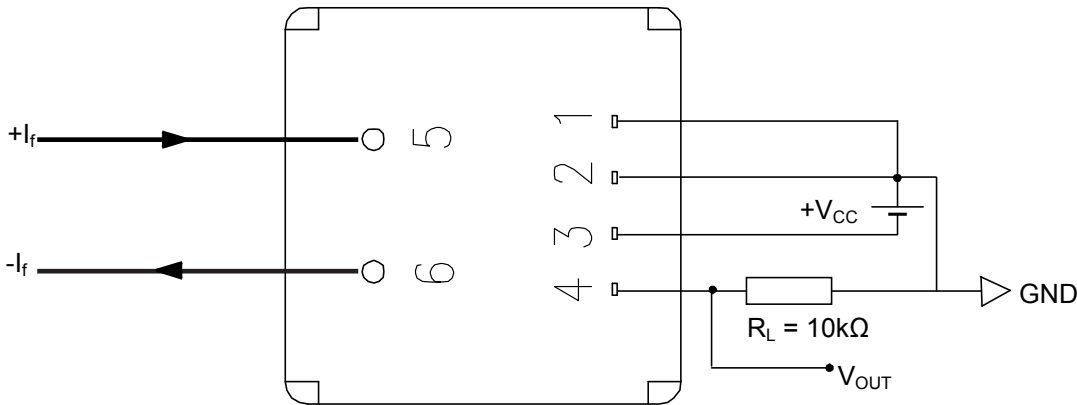

## Package & Weight Information

Weight	Pcs/box	Pcs/carton	Pcs/pallet
8g	100	600	9600